

Understanding the measurement uncertainties of the bicon/log hybrid antenna

Measurement uncertainty associated with the bicon/log hybrid antenna for radiated emissions and site validation tests relate to many factors, including height dependency, polarization and loading.

ZHONG CHEN

EMC Test Systems
Austin, TX

Since their first introduction in 1994 at the Roma International Symposium on EMC,¹ bicon/log hybrid antennas have become very popular in EMC labs worldwide. Because there are no band breaks in frequency sweep, test time and effort are reduced. EMC engineers have assumed that performance of these antennas is simply that of a biconical antenna at a lower frequency range until it transitions to a regular log periodic dipole array (LPDA) antenna at higher frequencies. Questions have been raised about this assumption, and some have suggested that a higher measurement uncertainty (U) should be used due to the characterization of the phase center position and antenna pattern variation from that of a dipole on which emission and site validation standards are based. Very limited research has been conducted on the uncertainty evaluation of these hybrid antennas, despite the fact that more and more EMC engineers have come to realize that predicting and reducing measurement uncertainty has become an important aspect of EMC testing.

Most antenna manufacturers and calibration labs provide individually calibrated antenna factors (AF) with associated U values. A thorough understanding of these values is essential. EMI and normalized site attenuation (NSA) tests are performed over a conducting ground plane. Calibration labs may be able to provide very accurate calibrations of the free-space AFs, which are intrinsic properties of the antennas. Studies have shown that antenna

performance can change by a few decibels over a ground plane, and this effect is antenna type specific. In many cases, the performance of a bicon/log hybrid antenna over a ground plane is different from that of a bicon or a log antenna. A good free-space AF with a low U does not always translate into a low U in the EMI or NSA measurement due to the influence from the conducting ground.

This article will address several aspects of measurement uncertainty related to the bicon/log hybrid antenna application. They are: the height dependency of the hybrid antenna AF above a conducting ground plane; the geometry and polarization-dependent AF and NSA measurement; active phase center variation with frequency; antenna beam pattern; and the comparisons of a bicon/log hybrid with separate bicon and log antennas. Some manufacturers also apply capacitive loading on the bow tie elements to improve the low frequency performance of these antennas. This article also explains how this loading impacts the measurement U.

HEIGHT/POLARIZATION DEPENDENCY ABOVE A CONDUCTING GROUND PLANE

AF is defined as the ratio of the incident electric field over the receive voltage at a 50-ohm load connected to the feed point of the antenna. The free-space AF is obtained when the antenna is in free-space and the incident electromagnetic field is a plane wave. The free-space AF is an intrinsic property of the antenna, just like the physical length of a ruler, and should not vary no matter how the calibration is performed. However, just like heat or cold can

change the length of a ruler, the environment in which the antenna is used can also impact the AF. EMI and NSA measurements are performed over a conducting ground plane, and unlike temperature, which does not change a ruler all that much, the ground plane can change the AF by as much as 2 or 3 dB depending on the polarization and height. Different types of antennas also interact with the ground plane differently, causing the effect on the AF to be antenna specific.

Figure 1 shows a traditional bicon/log hybrid antenna, while Figure 2 shows an enhanced model for improved low frequency performance. Let us use the traditional model shown in Figure 1 to illustrate the dependency of the AF on height above a conducting ground plane. Figures 3 and 4 show numerically-calculated AFs at heights of 1 m, 2 m, 3 m and 4 m for a horizontally or vertically-polarized antenna. Note again that the EMI or NSA measurements are typically performed for a

for different frequencies, AFs are different; for different polarizations, AFs are different; for different separation distances, AFs are also different.

height scanning from 1 m to 4 m. If we were to use a free-space AF or an AF calibrated at a fixed height to do a measurement at a different height, no matter how accurate the calibration is, there exists an error.

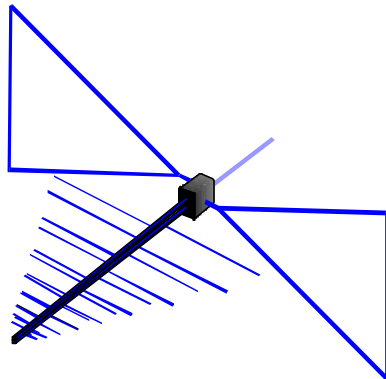

Figure 1. Traditional bicon/log hybrid antenna.

We may be tempted to say we just need to use a matrix of AFs, so that at each different height we could use a different AF. However, for different frequencies, AFs are different; for different polarizations, AFs are different; for different separation distances, AFs are also different. It becomes a practical issue for calibration in all these different cases and

requires applying a complicated multi-dimensional matrix of AFs during an EMI test.

Instead of this complicated web of AFs, is there an acceptable compromise if we are willing to sacrifice a little bit of accuracy? It turns out that the free-space AF provides an acceptable average. As shown in Figure 3, the free-space AF falls right in the middle for most of the frequencies. This is also why the ANSI, CISPR and other international standards have moved toward the use of free space AF for product EMI test in recent years. However, it is also clear that we may be able to get a near perfect free-space AF, but it would not be perfect for our typical EMI or NSA measurements, simply because a typical measurement condition is not free-space. For total measurement U, in addition to the antenna calibration U obtained from antenna calibration labs, we must assess additional uncertainty values for the antenna and geometry-dependent test setups.

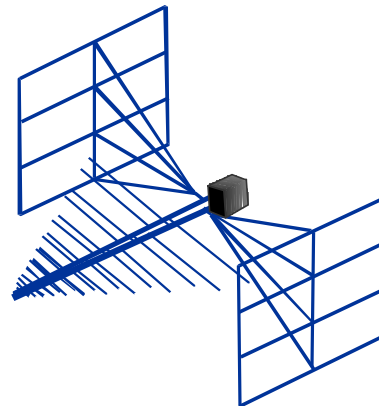

Figure 2. Enhanced model of the bicon/log hybrid antenna.

STANDARD SITE METHOD CALIBRATION AND IMPLICATIONS ON NSA MEASUREMENTS

ANSI C63.5 calibration calls for a three-antenna-method calibration over a ground plane, commonly known as the standard site method. In this measurement, the receive antenna is scanned in heights from 1 m to 4 m. NSA measurement

as defined in ANSI C63.4 is simply the reverse of the ANSI C63.5 antenna calibration procedure. The only significant difference is that for NSA measurement, the site is the unknown, where for antenna calibration, the AFs are the unknowns.

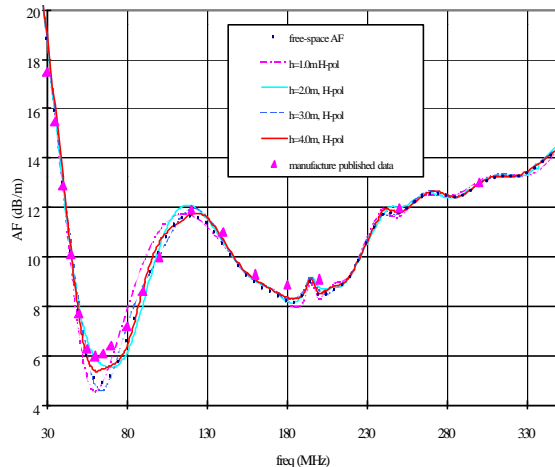

Figure 3. Numerically-calculated bicon/log AF at different heights for horizontal polarization above a conducting ground plane. Manufacturer-published data are also shown as triangles.

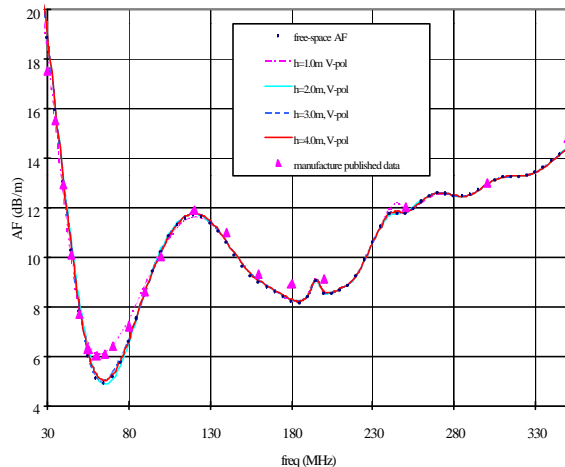

Figure 4. Numerically-calculated bicon/log hybrid AF at different heights for vertical polarization above a conducting ground plane. Manufacturer-published data are also shown as triangles.

A common question when following the NSA measurement procedures is "I calibrated my antennas very recently. When I use the AF to do my test, with separate bicons and log antennas, I can pass the NSA requirement, but

when I use the hybrid antennas, I failed the test. Is that due to my antennas or my site?" Other questions are "I need to calibrate my antennas for site validation; which AFs do I need?", and "Do I need free-space AF, 3-m or 10-m calibration, and how about height and polarization?"

It was explained above how AFs change under different geometries and how free-space AF can be used for product EMI test as an acceptable average. To better answer the above questions, we need to quantify exactly how much different geometries affect the performance of a specific antenna. For NSA measurement, since we are dealing with a tighter tolerance, we want to decrease our measurement uncertainties. We will show that the free-space AF approximation becomes inadequate. Let us first look at some antennas calibrated per the ANSI C63.5 standard site method. Figure 5 shows the resulting AFs for a separation distance of 3 m, with the receive antenna scanned from 1 to 4 m in height.

In the standard site method, the discrepancy results not only from the height variation, but also from other factors, such as the non-plane wave illumination of the receive antenna, mutual coupling between the transmit and receive antennas, and the dipole antenna pattern assumption made in the theoretical model.² As shown in Figure 5, using a single AF to do an NSA test for all these geometries is a crude approximation. One thing to note is that Figure 5 only shows the difference in the AF for a single antenna under different geometries.

For an NSA measurement, there are two antennas involved, transmit and receive. The resulting difference is the sum of two antennas. For example, at 180 MHz, the free-space AF is different from the AF for the vertical polarization ($h_1 = 1.5$ m) by 2 dB. If a free-space AF were to be used for an NSA site validation measurement, the NSA error just due to the AF difference would be 4 dB (2 dB from the transmit antenna, and 2 dB from the receive antenna). Thus, it is unlikely a site would pass the NSA 4 dB requirement under this condition.

This answers the first question of whether the NSA failure is due to the antenna or site: it is probably neither the site nor the antenna calibration that is at fault. Perhaps the answer lies in the method being used, and whether the correct AF is applied. Because the NSA procedure is simply the reverse of the procedure

for an ANSI antenna calibration, if the NSA geometry stays the same as the calibration geometry, the errors shown in Figure 5 exactly cancel.

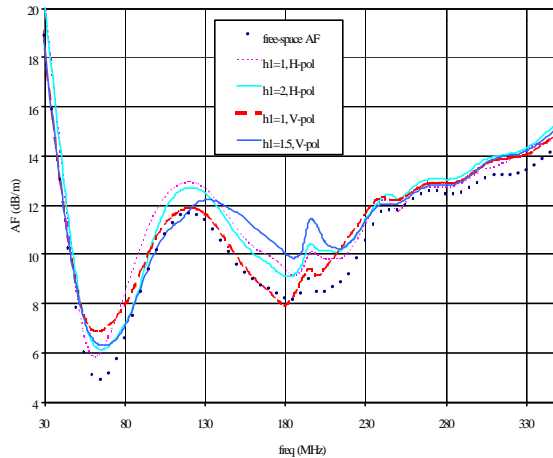

Figure 5. Numerically calculated bicon/log hybrid AF obtained using the 3-m ANSI C63.5 standard site method. The receive antenna is scanned from 1 to 4 m with a step size of 0.05 m. "h1" is transmit height.

This also answers the second question of which antenna calibration is needed for a site validation test; the geometries for site validation and antenna calibration need to be identical to get the lowest measurement uncertainty. However, there is one catch. The antenna calibration site needs to be very good, because any errors generated in the antenna calibration will be transferred to the site validation test.

Let us look at the results in Figure 5 from another perspective. If we assume that the transmit antenna is the equipment under test for an emission measurement, and we use the free-space AF to qualify the EMI from this piece of equipment, the difference between the different geometries and the free-space AF is the error in our measurement. For the example given in Figure 5, this error is 2 dB in some cases. The biconical antenna was also studied for the same circumstances,² and the errors were shown to be about 1 dB smaller. For lowest U, a biconical antenna is recommended.

ACTIVE PHASE CENTER VARIATION WITH FREQUENCY

The radiating elements for a bicon/log hybrid antenna move from the bigger elements in the

back to the smaller elements in the front as the frequency goes up. The radiating position for a specific frequency is commonly referred to as the active phase center. It appears that the electromagnetic fields are radiated from that center.

Because the phase center moves with frequency, other common questions people ask are: "Where do I measure the distance from the bicon/log hybrid antenna for my test? Should I measure from the tip of the antenna or from the center of the antenna?" A typical answer is to measure from the tip for an immunity test, and from the center for an emission measurement, as specified by the ANSI, CISPR and IEC standards. It is rather clear that this position is just an approximation during the frequency sweep. Thus, uncertainties are introduced in the measurements by assuming a fixed position.

The question arises for bicon/log hybrid antennas from different manufacturers; these antennas may not have the same design or the same length. Are their uncertainties different in an EMI test? The answer is absolutely yes. The next question is whether this error can be estimated. This question may be answered by simply looking at the E_{\max}^d formulation.*

If we can assume that a bicon/log hybrid antenna acts like a series of dipoles radiating in different positions at different frequencies, E_{\max}^d should not be calculated for a fixed distance. For example, when we perform a 3 m calibration below 100 MHz, the bow tie elements are active. If the antenna is 1 m long and the reference position is the center of the antenna, we are in fact performing a 4-m test (0.5 m addition for each antenna). Figure 6 shows the E_{\max}^d values for a horizontally polarized antenna with the transmit antenna at 1 m height. It shows that more than 2 dB of error can be expected just due to the active elements being different from the reference point.

* E_{\max}^d is a concept introduced by Smith, German, and Pate³ and later adopted by the ANSI C63 standard site method and NSA formulation. It represents the maximum electric field in a height scan for a tuned dipole with a radiated power of 1 pW.

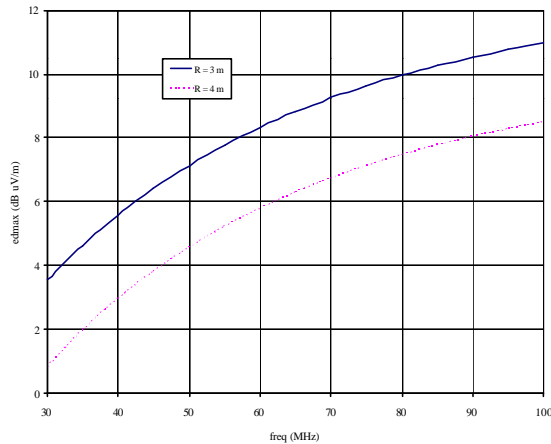

Figure 6. E_{\max}^d for 3 m and 4 m separation distance for a horizontally-polarized antenna. The transmit antenna height is 1 m, and the receive antenna height is scanned from 1 to 4 m.

For antenna calibration, if the active center can be accurately characterized, applying E_{\max}^d for the correct distances will rectify the error. For a radiated emission test, if the free-space antenna factor is used, this error cannot be amended, and becomes part of the measurement uncertainty. On the other hand, if a biconical or dipole antenna is used, this phase center is well defined, and a lower measurement uncertainty is achieved. A log antenna can suffer from the same phase center error, but conceivably, a single log antenna is shorter than the hybrid. The phase center error would be smaller. For a critical test where low measurement uncertainty is desired, a simple dipole, bicon and/or log antenna are preferred over the hybrid antenna.

ANTENNA DIRECTIVITY AND BEAM PATTERN

The intent of the ANSI C63.4 NSA and emission measurement is to use a field sensor with a dipole pattern (because the Roberts' Dipole is the undisputed reference). If the antenna pattern is different from a dipole, it should not be an issue if the measurement were performed in a free-space environment as long as we can keep the antenna pointing to the equipment under test at all heights (boresighting).

For a measurement over a conducting ground plane, however, there is a signal reflection from the ground plane. The reflected

field enters the antenna pattern at an angle. The addition of the direct and reflected signal will not add the same way if the antenna pattern is different. There are certain pattern variations from that of a dipole for the hybrid antenna.¹ Any deviation due to the antenna pattern needs to be treated as a source of measurement uncertainty. Bicon antenna patterns have been illustrated to be close to those of dipoles,⁴ so, again, this error is smaller for the biconical antennas.

CAPACITIVE-LOADING(LOW-FREQUENCY IMPROVEMENTS) FOR CERTAIN BICON/LOG HYBRID

The VSWR for a hybrid such as the sample shown in Figure 1 is on the order of 20:1 at the 30 MHz range, which means that about 80% of the forward power is reflected back to the source. To generate a certain field level for a radiated immunity test, a huge amplifier is sometimes needed. Several manufacturers introduced capacitive-loading to their antennas, such as shown in Figure 2, to improve the mismatch condition. This improvement is most useful for radiated immunity tests.

For emission tests, the loading elements can couple strongly with the ground when polarized vertically. Figure 7 is an example of the antenna factors at different heights for a vertically polarized antenna with an L-shaped enhancement. This L-shaped enhancement is a variation of the T-shaped bow tie shown in Figure 2. Even though we could treat such coupling as part of the measurement uncertainty, this value would be unacceptably large, as is the case in Figure 7 (on the order of 5 dB).

The solution for making such an antenna suitable for both radiated emission and radiated immunity testing is to make the end-loadings removable. For immunity testing, the end-loadings are left on to gain the better match (thus requiring a smaller amplifier for a fixed field level). Since the purpose of the immunity test is to generate a given field level, as long as we can measure the generated field, this coupling is not an issue. In addition, most immunity tests are performed in a fully-lined anechoic room, or over a partially absorber-lined ground plane, and this coupling is not as significant.

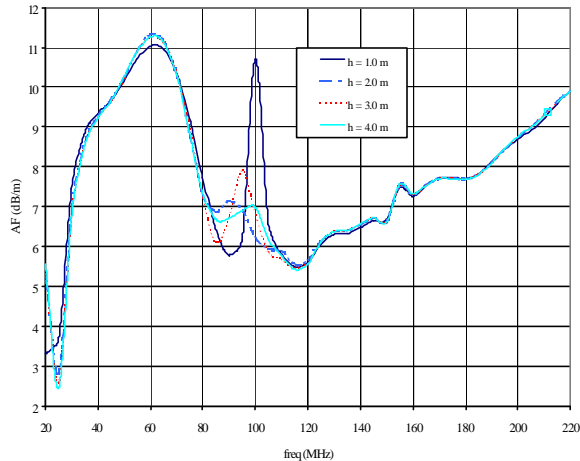

Figure 7. Numerically-modeled AF for a vertically polarized bicon/log hybrid with an L-shaped end-loading.

For an emission measurement, the end-loading should be removed. The antenna in that case would simply perform like a traditional bicon/log hybrid antenna. One thing to note is that the antenna does not need to be calibrated for use in immunity mode, thus saving the cost of calibration for both emission and immunity configurations.

CONCLUSIONS

This article has presented several issues of measurement uncertainties related to the bicon/log hybrid application. Many general measurement uncertainty related issues are not discussed here since they are not particular to this type of antenna. These include cable mismatch uncertainty, site irregularity, site edge refractions, etc. In an actual measurement, these factors all play important roles in the total measurement uncertainty evaluation. On the other hand, an important issue which tends to be ignored by many EMC engineers is the antenna-specific uncertainties. In most cases, care must be taken when using different antennas and their associated antenna factors. A compromise must be made between the ease of measurement and the accuracy of the measurement.

REFERENCES

1. S. J. Porter, A. C. Marvin, "A New Broadband EMC Antenna for Emissions and Immunity," *Roma International Symposium on EMC; Rome, Italy, September 1994.*

2. Z. Chen, M. Foegelle, "A Numerical Investigation of Ground Plane Effects on Biconical Antenna Factor," *IEEE International Symposium on EMC; Denver, Colorado, 1998.*

3. A. A. Smith Sr., R. F. German, and J. B. Pate, "Calculation of Site Attenuation from Antenna Factors," *IEEE Transactions on Electromagnetic Compatibility, Vol. 24, No. 3, August 1982, pp. 301-311.*

4. M.J. Alexander, M. H. Lopez, M. Salter, "Getting the Best out of Biconical Antennas for Emission Measurements and Test Site Evaluation," *IEEE International Symposium on EMC; Austin, Texas, 1997.*

ZHONG CHEN received his M.S.E.E. degree in electromagnetics from the Ohio State University at Columbus. He has been with EMC Test Systems (ETS) since 1996, where he is now a senior electromagnetics and antenna engineer. He is a member of the IEEE AP, MTTs and EMC Societies. (512) 835-4684 ext. 627; E-mail: zhong.chen@emctest.com.