

Model 1052

Antenna Tower Positioning System

User Manual



(Antenna not included)

 **ETS-LINDGREN**[™]
An ESCO Technologies Company

ETS-Lindgren L.P. reserves the right to make changes to any product described herein in order to improve function, design, or for any other reason. Nothing contained herein shall constitute ETS-Lindgren L.P. assuming any liability whatsoever arising out of the application or use of any product or circuit described herein. ETS-Lindgren L.P. does not convey any license under its patent rights or the rights of others.

© Copyright 1990–2010 by ETS-Lindgren L.P. All Rights Reserved. No part of this document may be copied by any means without written permission from ETS-Lindgren L.P.

Trademarks used in this document: The *ETS-Lindgren* logo is a trademark of ETS-Lindgren L.P.

Revision Record

MANUAL,MODEL 1052 | Part #399163, Rev. D

Revision	Description	Date
A	Initial Release	June, 1990
B	Updated assembly instructions; half-size format	April, 2008
C	Updated assembly instructions and illustrations	July, 2008
D	Added <i>Using Guy Ropes</i> content; updated <i>Specifications</i>	March, 2010

Table of Contents

Notes, Cautions, and Warnings	v
1.0 Introduction	7
ETS-Lindgren Product Information Bulletin	7
2.0 Maintenance	9
Annual Calibration	9
Service Procedures	9
3.0 Specifications	11
Load Capacity	11
Physical Specifications	11
4.0 Assembly Instructions	13
5.0 Operation	21
Before You Begin.....	21
Using Guy Ropes.....	22
Appendix A: Warranty	23

This page intentionally left blank.

Notes, Cautions, and Warnings

	<p>Note: Denotes helpful information intended to provide tips for better use of the product.</p>
<p>CAUTION</p>	<p>Caution: Denotes a hazard. Failure to follow instructions could result in minor personal injury and/or property damage. Included text gives proper procedures.</p>
<p>WARNING</p>	<p>Warning: Denotes a hazard. Failure to follow instructions could result in SEVERE personal injury and/or property damage. Included text gives proper procedures.</p>



See the ETS-Lindgren *Product Information Bulletin* for safety, regulatory, and other product marking information.

This page intentionally left blank.

1.0 Introduction

The **ETS-Lindgren Model 1052 Antenna Tower Positioning System** is designed for portable antenna positioning in EMC compliance testing.

A hand winch and pulley drive system elevates the antenna carrier from one to four meters. Maximum carrier load capacity is 11.3 kg (24.91 lb) on the tip of the cross boom. For loads measured on the center of the cross boom, the capacity is 22.7 kg (50.04 lb).



The mast is constructed of a high density fiberglass reinforced polymer with a high degree of immunity to structural deterioration from environmental elements. The base is an aluminum four-leg design for maximum support and portability. The design of the Model 1052 allows easy assembly and usage.

ETS-Lindgren Product Information Bulletin

See the ETS-Lindgren *Product Information Bulletin* included with your shipment for the following:

- Warranty information
- Safety, regulatory, and other product marking information
- Steps to receive your shipment
- Steps to return a component for service
- ETS-Lindgren calibration service
- ETS-Lindgren contact information

This page intentionally left blank.

2.0 Maintenance

CAUTION

Before performing any maintenance, follow the safety information in the ETS-Lindgren *Product Information Bulletin* included with your shipment.



Maintenance of the Model 1052 is limited to external components such as cables or connectors.

Routinely inspect the winch rope for wear. If wear or any deterioration is found, replace the rope immediately.

If you have any questions concerning maintenance, contact ETS-Lindgren Customer Service.

Annual Calibration

See the *Product Information Bulletin* included with your shipment for information on ETS-Lindgren calibration services.

Service Procedures

For the steps to return a system or system component to ETS-Lindgren for service, see the *Product Information Bulletin* included with your shipment.

This page intentionally left blank.

3.0 Specifications

Load Capacity

Maximum Carrier Load Capacity	
On Tip of Cross Boom:	11.3 kg (24.91 lb)
On Center of Cross Boom:	22.7 kg (50.04 lb)

Physical Specifications

Nominal Height:	4 m (13.12 ft)
Overall Height:	7 m (22.96 ft)
Weight:	34.47 kg (76.0 lb)

This page intentionally left blank.

4.0 Assembly Instructions

CAUTION

Before connecting any components, follow the safety information in the ETS-Lindgren *Product Information Bulletin* included with your shipment.



Prior to assembly and operation of the Model 1052 Antenna Tower Positioning System, read *Operation* on page 21.

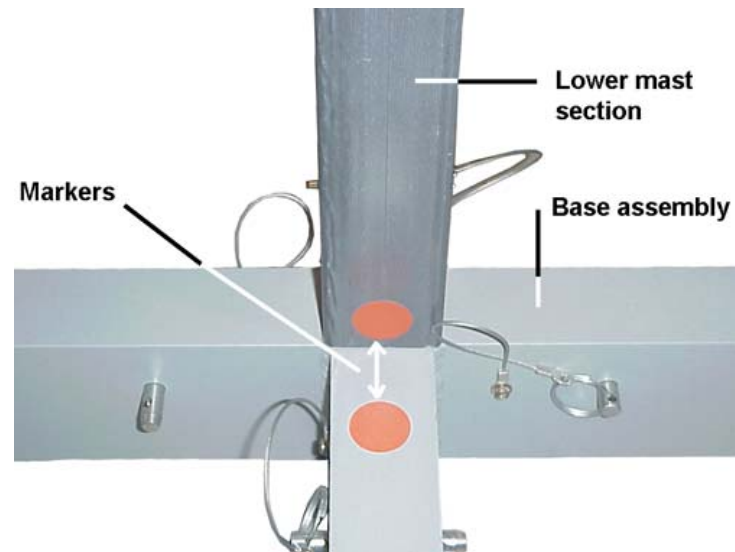

1. **Attach lower mast section to base assembly**—Install the lower mast onto the center post of the base assembly, aligning the markers.

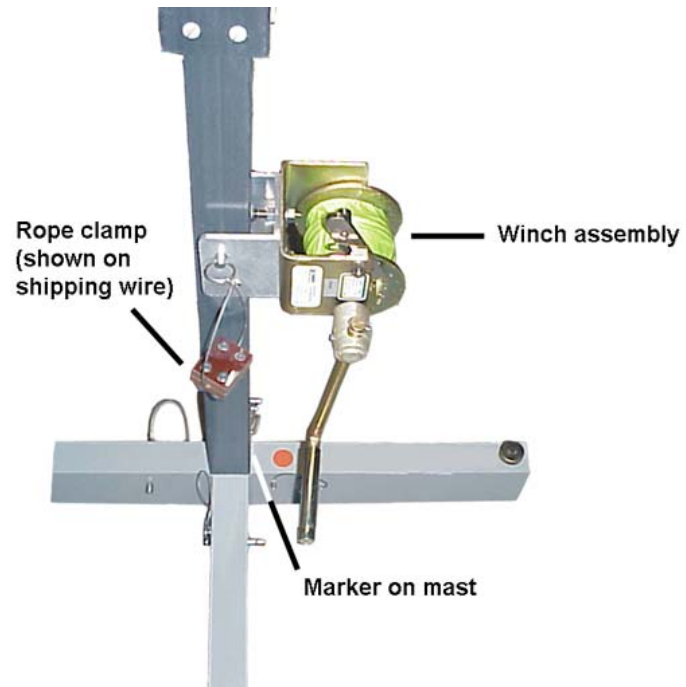

The rope clamp is located on a wire (as shown) for shipping purposes only. During step 6 of the assembly instructions you will move the rope clamp to the rope.

2. Attach winch assembly to lower mast section

- Install the winch assembly onto the lower mast with the crank side of the winch aligned with the marker on mast. Place the crank on either side of the mast, as desired.

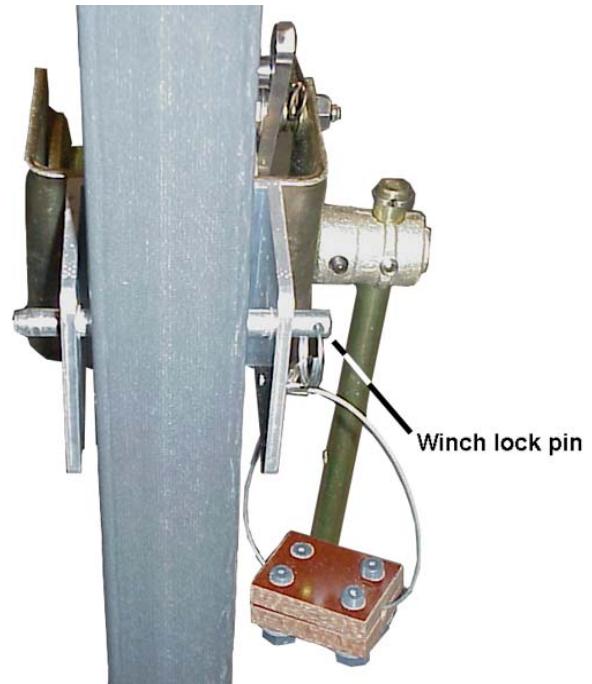

- Secure winch with winch lock pin by sliding the pin through the winch and mast.

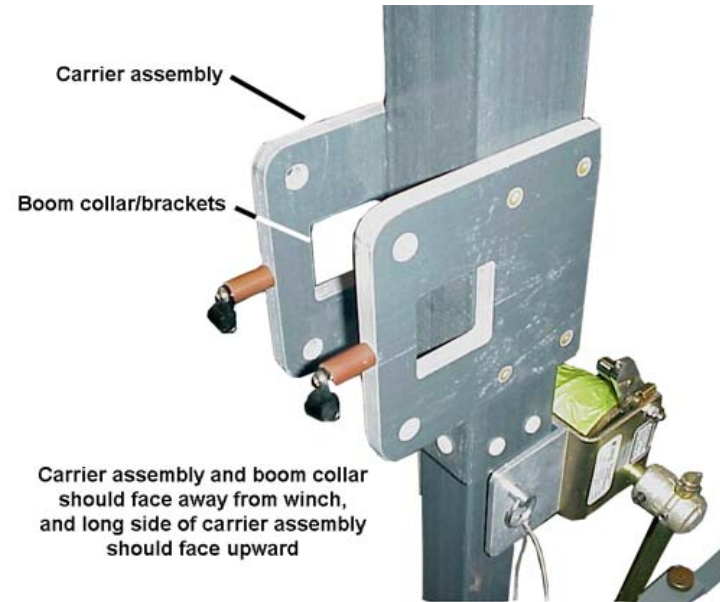

3. Slide carrier assembly onto lower mast.
 - Carefully place the mast and base assembly onto the side.
 - Slide the carrier assembly over the lower mast.
 - The carrier assembly and boom collar/brackets should face away from the winch. The long side of the carrier assembly should face upward.

- 4. Install upper mast section**—With the pulley at the top, insert the upper mast into the lower mast, and align the markers.



- 5. Thread winch rope from winch, through pulley, and down the other side to the carrier.**

- Remove the clevis pin at the top of the upper mast.
- Unwind the winch rope to the top of mast and place it over the pulley.
- Secure the rope in the pulley groove with the clevis pin.

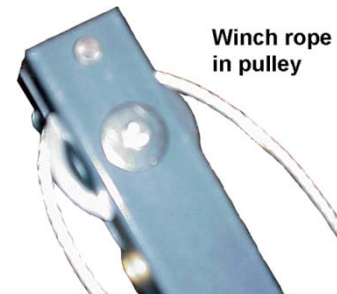

**Secure rope
to carrier at
boom brackets**

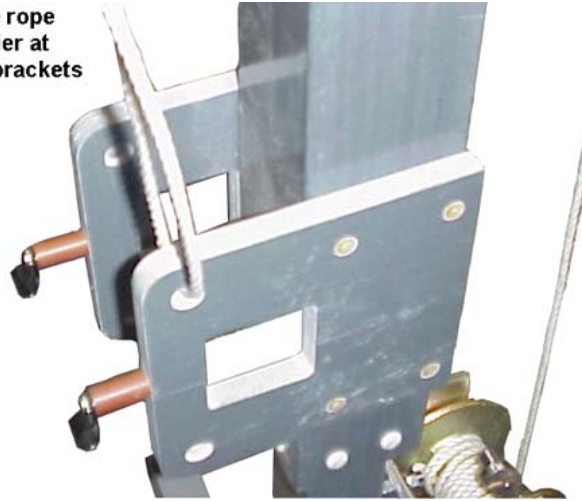

- Continue to unwind rope until there is enough rope to reach the winch.
- Secure the rope with a loop to the carrier assembly at the boom brackets. Use the rope clamp to secure.

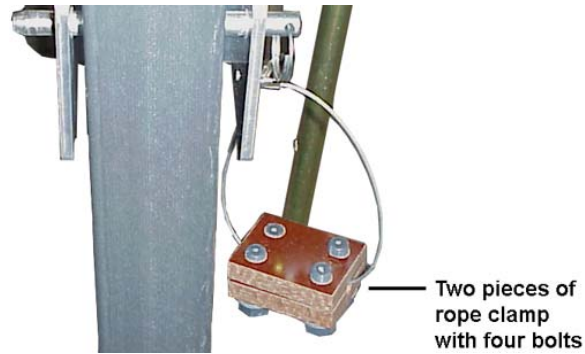

6. Move rope clamp from shipping wire to rope.

- Remove the four bolts from the rope clamp to separate the two pieces.
- About two inches above where the rope is secured at the boom brackets, place one piece of the rope clamp on each side of the rope.
- To clamp the rope, re-attach the two pieces with the four bolts.

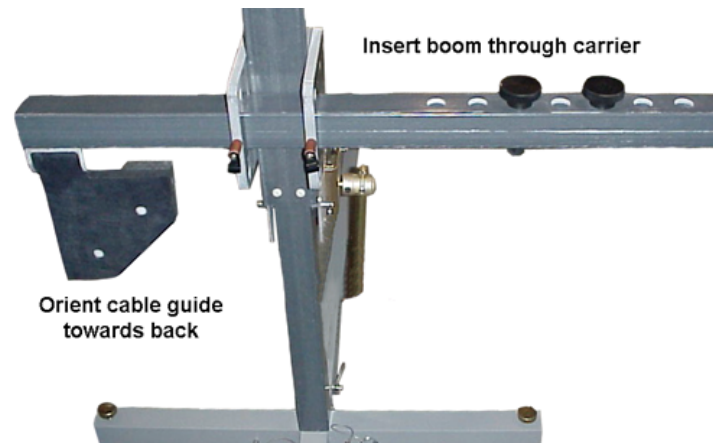

- 7. Attach boom**—Insert the boom through the boom brackets on the carrier with the cable guide oriented towards the back.

8. Install extension legs.

- Position the carrier at the winch assembly.
- Raise the entire unit until it is in an upright position, resting on the base.
- Install the extension legs into the base with each leg oriented so the pin hole is nearest to the bottom side of the leg.
- Secure each extension leg with a lock pin.
- Use thumbscrews to make vertical adjustments to legs.



- 9. Thread cable through cable guide**—Insert the feed cable for the antenna into the cable guide to reduce stress on the cable and antenna connector.

Mount an antenna to the boom by threading the mounting knobs up through the holes in the boom and into the mounting receptacle on the antenna.

To install guy ropes, see *Using Guy Ropes* on page 22.

5.0 Operation

Before You Begin

CAUTION

Before placing into operation, follow the safety information in the ETS-Lindgren *Product Information Bulletin* included with your shipment.

CAUTION

Follow these guidelines prior to operating the Model 1052.

- Make sure that the winch is always securely fastened to the mast.
- Do not exceed load capacity. See *Specifications* on page 11 for maximum load capacity measurements.
- Routinely inspect the winch rope for wear. If wear or any deterioration is found, replace the rope immediately.
- Do not overload, kink, or knot the rope.
- Do not alter or customize the mast or winch assemblies.
- Do not walk under a load that is suspended in the air.

Using Guy Ropes

Additional rope is included with your Model 1052 Antenna Tower Positioning System for installing guy ropes. You should use guy ropes for extra mast stability when using the Model 1052 outside, with heavy loads, and other situations when extra stability is required.

To install guy ropes:

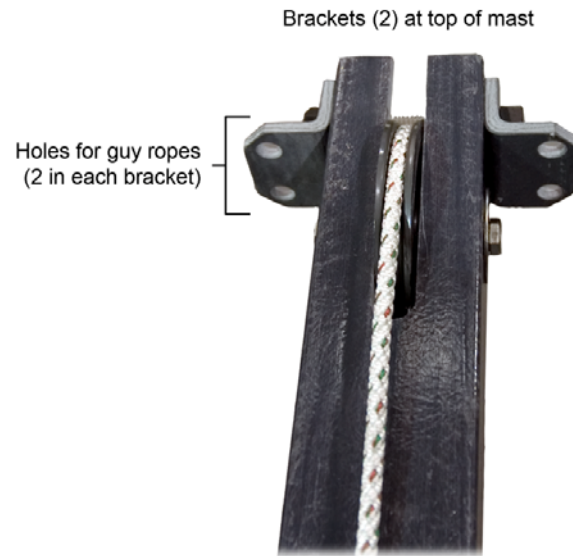

1. Thread guy ropes through holes in brackets at top of mast. Use two to four guy ropes, as required.
2. Securely tie ends of guy ropes to a fixed object, as required.

Appendix A: Warranty



See the *Product Information Bulletin* included with your shipment for the complete ETS-Lindgren warranty for your Model 1052 Antenna Tower Positioning System.

DURATION OF WARRANTIES FOR MODEL 1052

All product warranties, except the warranty of title, and all remedies for warranty failures are limited to two years.

Product Warranted	Duration of Warranty Period
Model 1052 Antenna Tower Positioning System	2 Years